



# Product Catalog

standing • seating • desks • stools  
toileting • bathing • changing • showering

supporting children and  
their families **for life**



# welcome

Since 1986, Smirthwaite Ltd has developed and retained its reputation as one of the leading designers and manufacturers of pediatric equipment, both in the United Kingdom and internationally. Strengthening this position, we launched Smirthwaite USA LLC in 2012. In that time, we have dedicated ourselves to finding and providing effective solutions that offer significant benefits to babies, children and young adults in their daily lives. Working closely with children, parents, caregivers and therapists, we have developed a comprehensive and innovative range of seating, standing, toileting, bathing, changing and showering products.

## Our mission

Is to work together to enhance the lives of people with additional needs using lovingly created specialist equipment to help each person shine.

## Lovingly created

Respected throughout the industry for our technical expertise, we play an active role in helping to shape standards and best practice. We believe in well-made pediatric products that are easy to use and, importantly, can stand the test of time. For added convenience, we have produced product user guides and videos which are available to download.

Our durable products are available in a variety of amazing colours to brighten up any child's room (or to simply to allow them to choose and enjoy their favourite colour chair, for example).

Our bespoke products come in a variety of amazing colours to brighten up any child's room (or to simply to allow them to choose and enjoy their favourite colour chair, for example).

We have a very close relationship with therapists, children and parents which helps us to establish exactly what is required from our products.

Our designs reflect this expertise and provide numerous clinical benefits while promoting social inclusion and independence.

Our dedicated team are always on hand to provide free, no-obligation assessments and will work with you, your therapist and your child to find the very best solution to their needs. Where required we will make changes to our products to suit your child's exact requirements.

[www.smirthwaite.com](http://www.smirthwaite.com)





# supporting children & their families for life

## Easy to clean

All of our products are easy to clean. Our wooden chairs have antimicrobial properties that ensure surfaces are kept hygienic. This helps to reduce any risk of cross infection and is especially useful in multi-user environments such as nurseries and schools.

All our upholstery is carefully chosen and all contain antibacterial agents that help against the spread of MRSA, E coli and C dif.

## Innovation in our design

Pediatric equipment is often overly complex, difficult to use and expensive to maintain. At Smirthwaite, we believe in well made, easy to use products that stand the test of time. Through close consultation with leading therapists, parents and users, we ensure our designs offer numerous clinical benefits while maintaining a customer-centric and innovative approach. All products come with a 2 year warranty as standard.

## Inquiries or Orders

You can order our products swiftly and easily online via our website below; or call our friendly Customer Services team on

212 541 2455

info@smirthwaite.com



## seating

asiento	6
sunni	9
brookfield	10
hardrock	11
heathfield	14
corner chair / hip spica	17
felix	18
juni	20
zoomi / zoomi +	24

## standing

buddy	28
star	29

## toileting & bathing

bath corner chair	31
combi	32

## desks & stools

desks	26
wheely stool	27

## changing & showering

easi-lift changing bench	36
hi riser	38
hi riser showering	40
mobi changer	42
mobi heavy duty changer	44
mobi showering trolley	46
shower stretcher	48

## added extras

sandals	50
---------	----



\*DISCLAIMER - Please note there maybe an extended lead time on larger orders that would require transportation on a container versus being able to ship via UPS from the UK.

# Asiento

## NEW!

Developed alongside input from clinical professionals, the Asiento is a strong and highly adjustable chair suitable for children from 1 year old to young adults with moderate to complex needs. Created to improve postural support and symmetry, the Asiento delivers many clinical benefits while being functional too.

### It's durable

Accessories are attached to the chair's strong central column making the Asiento robust and sturdy.

### Dynamic back

The dynamic back is great for those who have dystonic body movements. The backrest will move with the user and then gently return them to the correct sitting position.

### Easy to use tray

The universal tray is easily attached to the armrests. The tray adjusts with the armrests to allow for use on all seat widths and also depths, providing the best fit possible for all sized users.

### Quiet electric hi-lo base

With the electric hi-lo base, users can smoothly raise and lower the chair to the desired height with a user-operated remote control. It's quiet too, helping those who are sensitive to sound.

### Closer contact

The open design of the chassis and pushbike handles allows carers to get close to the backrest. This is especially useful for upper-limb therapy, crossing midline, administering care and calming the user after an epileptic fit or when anxious.

## designed specifically for children, teenagers and young adults with moderate to complex needs

### New deluxe colour range

The following colour options apply to the Asiento:

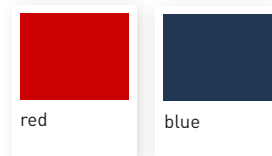

Pressure care relief technology in partnership with Levitex has been applied to the Asiento.



### Standard key features



Bodypoint harness



Adjustable side supports



Dynamic back & lap strap



Flip-up footrest & multi-positional leg rests

### Asiento technical data

all dimensions in mm unless otherwise stated

	Size 1	Size 2	Size 3
<b>Code</b>	<b>1011</b>	<b>1012</b>	<b>1013</b>
Max user weight	80	176	265
Seat depth (min-max)	7.4-13.2	11.4-18.5	14.4-23.6
Seat width	11.2	16.1	18.9
Back rest height	13.8-16.9	16.5-20.1	19.3-23.2
Seat height from floor	11.4-22.2	11.4-22.2	19.3-29
Lower leg length (seat to footplate)	8.3-12.6	8.3-12.6	19.3-22
Armrest height (min-max from seat)	4.3-12.8	4.3-12.8	4.3-12.8
Lateral supports travel adjustment	1.9	2.6	2.6
Hip guide travel adjustment	2.7	2.7	2.7
Abduction pad travel adjustment	1.9	1.9	1.9
Adduction pad travel adjustment	1.9	1.9	1.9
Chest width	1.9-13.8	9.8-15.4	12.2-17.3
Armrest angle (forwards/backwards)	90°/90°	90°/90°	90°/90°
Back angle (forwards/backwards)	10°/32°	10°/32°	10°/32°
Footrest angle (forwards/backwards)	90°/20°	90°/20°	90°/20°
Footplate Angle (plantarflexion/dorsiflexion)	45°/25°	45°/25°	45°/25°
Abduction angle	23°	23°	23°
Adduction angle	23°	23°	23°
Tilt in space (forwards/backwards)	10°/20°	10°/20°	10°/20°
Tray size	30 x 17.3	30 x 17.3	30 x 17.3
Seat width between thighs	9-14.6	11.4-15.4	13.7-17.5



enhancing lives...



# sunni

## School cafeteria chair

Sunni is all about inclusion at meal times at school. It gives children the opportunity to eat and socialize with their friends during school break times instead of eating separately in their own chairs.

## Working with Cerebra

It has been designed along side the Charity Cerebra. Families with a child who has a brain condition face challenges every day. Just to learn, play, make friends, enjoy and experience the world can feel difficult, sometimes impossible. But we believe challenges can be over come.

Cerebra's vision is that every family that includes a child with a brain condition will have the chance to discover a better life together.

Their mission is to listen to families that include children with brain conditions. They use what they tell them to inspire the best research and innovation. Cerebra helps them put the knowledge into practice so they can discover a better life together.

## Benefits of Sunni

- Designed to fit most cafeteria chairs
- Armrests fold away
- Three point harness
- Wipe clean seat pads
- High backrest for taller children
- Easy to transport and maneuver
- Can be used at home and in school
- Available in four vibrant colors

## Sunni technical data

all dimensions in inches unless otherwise stated

Size	1	1 HB	2	2HB
Seat depth	8.2	8.2	10.1	10.1
Seat width	8.8	8.8	10.8	10.8
Back height	9.9	13.8	11.1	16
Armrest height	5.9	5.9	6.8	6.8
Back angle (°)	3.7	3.7	3.7	3.7
Max user weight (lbs)	33	33	55	55
Product weight (lbs)	6.6	7.7	8.8	9.9



Pictured: Sunni with footrest

## Optional footrest

An optional footrest is available to give support to the legs when sitting at the table.

## Colors





# brookfield

## NEW configurations



We heard your feedback and have made necessary adjustments to meet your needs. Our new brookfield and hardrock specifications offer better value and are more cost-effective with quicker lead times, without compromising quality. Expect less fuss and fewer accessories, making it easier to use. Take a look...

### New brookfield specifications

- Low, moulded back
- Contoured seat with buckle strap
- Includes standard 2 point strap
- Ocean blue

### Increased stability

The Brookfield is a robust chair for children from an early age to young adults who require moderate levels of postural support when seated. The Brookfield has a unique moulded back as standard to promote central alignment while your child is seated.

### Greater adjustability

The Brookfield offers seat height and depth adjustability. As an additional feature, the back can also be adjusted in height. This allows even greater flexibility and enables the chair to grow with your child.

### Perfect for customization

Each child is unique. The Brookfield has been carefully designed to provide your child with a high level of customization; this means that the needs of your child are brought to the forefront. By using the chair and the accessories together we can offer a highly tailored solution.

### Brookfield technical data

all dimensions in inches unless otherwise stated

Item #	Size*	Seat to floor height**	Width	Seat depth	Back height	Max user weight (lbs)
6571	1LB	10.0 - 13.0	12.8	8.7 - 12.6	14.4 - 19.3	121.3
6573	2LB	11.0 - 15.0	14.4	10.8 - 15.2	16.1 - 20.9	143.3
6575	3LB	13.6 - 17.5	17.1	14.0 - 18.3	17.7 - 23.2	165.3
6577	4LB	16.7 - 22.6	17.1	16.7 - 22.4	19.9 - 25.4	187.4

\*\*Height of chair with contoured seat.

# brookfield accessories



**Pommel**  
ITEM # PL010 & PL012  
Encourages hip abduction



**4 mobile legs with 3in casters**  
ITEM # LG001 - LG004  
Casters can be locked



**Reversible footboard**  
ITEM # FB002 - FB004  
Provides foot support & prevents unwanted chair movement



**Adjustable footrest**  
ITEM # FR002 - FR004  
The sides help to keep feet contained. Easy height adjustability



**Folding footrest<sup>1</sup>**  
ITEM # FR015 - FR017  
Facilitates standing transfer  
Foot plates fold away to the side



**Footplate & straps<sup>2</sup>**  
ITEM # FP003 - FP005  
Ensures that feet are firmly in position



**Adjustable height push handle**  
ITEM # PH018, PH020 & PH022  
For optimum push position

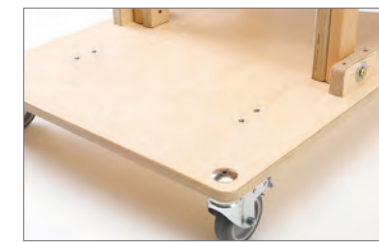

**Mobile dolly base**  
ITEM # DL002 - DL004  
Easy to manoeuvre with swivel multi-positional casters



**Pelvic cushions single or double thickness (pair)<sup>3</sup>**  
Provides hip and thigh support  
Available in various sizes



**Headrest or back extension**  
ITEM # HR004



**Knee blocks**  
ITEM # KN001  
Provides knee position  
Encourages hip abduction



**Tray**  
ITEM # TR003 - TR005  
Provides trunk support  
Additionally can be used for activities.

<sup>1</sup> Must be factory fitted at the time this product is ordered

<sup>2</sup> Only available in conjunction with a Mobile dolly base, Reversible footboard or Skis with half & full footrest

<sup>3</sup> Available as double cushions (pair) size 1+1in, 1.5+1in & 2+1in and singular cushions (pair) size 1in, 1.5in & 2in - please ask for ITEM #'s

# harness measurements

brookfield, heathfield & combi

# harness measurements

samba & hardrock

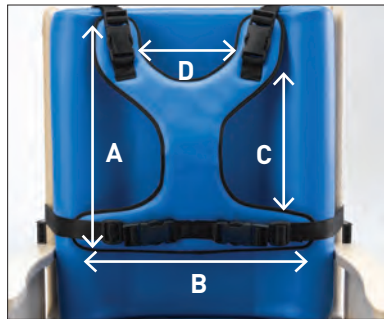

**Teenage harness**

Size	1	3
A (cm)	31	36
B (cm)	28	34
C (cm)	18	23
D (cm)	15	16



**Zipped jacket**

Size	1	2	3
A (cm)	7	9	11
B (cm)	24	29	33
C (cm)	25.5	32	35.5
D (cm)	7	9	11
E (cm)	5	5	5.5



**Butterfly harness**

Size	One Size
A (cm)	15
B (cm)	13



**Soft cross harness**

Size	1	2	3	4
A (cm)	46	51	57	63
B (cm)	5	5	5	5

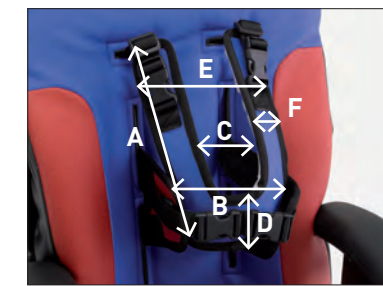

**Shoulder harness for the mid-line harness**

Size	1	2	3	4
A (cm)	22	22	22	28
B (cm)	16	16	16	22
C (cm)	16	16	16	16
D (cm)	5	5	5	7
E (cm)	27	27	27	27
F (cm)	5	5	5	6

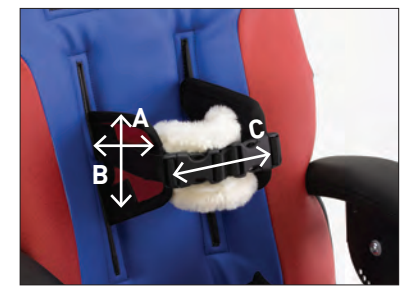

**Mid-line support harness with sheepskin pad**

Size	1	2	3	4
A (cm)	16	16	16	20
B (cm)	12	12	12	12
C (cm)	7 - 17	7 - 17	7 - 17	7 - 17

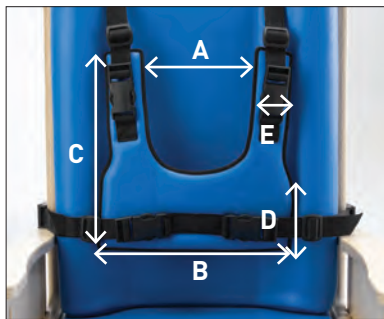

**Bib harness (padded)**

Size	1	2	3
A (cm)	11	14	17.5
B (cm)	23	26.5	32
C (cm)	22	28	31
D (cm)	9	13	15.5
E (cm)	6	6.5	7.5

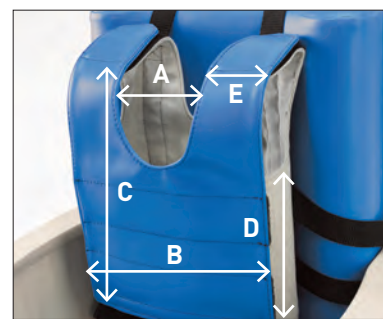

**Waistcoat harness**

Size	1	2	3
A (cm)	5	10	13
B (cm)	15	20	25.5
C (cm)	31	39	40
D (cm)	10	15	22
E (cm)	5	5	6.5
F (cm)	63	78	98

F = circumference front to back

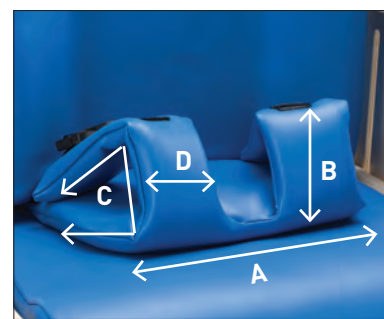

**Groin harness**

Size	1	2	3
A (cm)	24	27	32
B (cm)	17.5	25	28
C (cm)	37.5	47	60
D (cm)	6.5	8	9
Weight	150g	200g	300g

Smirthwaite harnesses offer comfort whilst maintaining secure positioning in all our seating systems. A range of colours and fabrics are available and 'made to measure' solutions and modifications can be made upon request.

Designed for use on Smirthwaite products only.

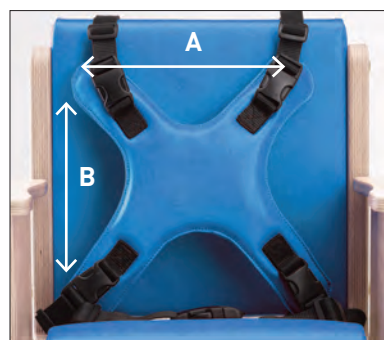

**4-point harness**

Size	1	2	3
A (cm)	23	28	29
B (cm)	28	28	30





# hardrock

## NEW configurations



### New hardrock specifications

- Low back
- Fully slotted
- Standard 2 point lap strap
- Anti thrust cushions
- Ski transporter base
- Blue



### Robust and durable

The Hardrock is an extremely durable and robust chair that has been specifically designed for children who are prone to rock repetitively. The Hardrock provides moderate levels of postural support and is suitable for both school and home environments.

### Tailoring to the child's needs

It can be a challenge to engage children with complex learning difficulties in educational and everyday activities. The Hardrock tackles this issue and offers a positive solution. It provides a safe environment and one that is conducive to learning.

### Posture matters

The Hardrock uses an anti-thrust system and anterior pad to provide secure postural management within clearly defined boundaries. Thoracic supports and stabilizers are available for children who exhibit sideways motion.

### Hardrock technical data

all dimensions in inches unless otherwise stated

Item #	Size	Seat to floor height	Width	Seat depth	Back height	Max user weight (lbs)	Product weight (lbs)
8202	2	10.2 - 16.1	13.8	11.8 - 16.3	19.3	132.3	80
8203	3	11.4 - 17.3	16.9	14.6 - 19.1	22.4	154.3	90
8203LB (low back)	3	11.4 - 17.3	16.9	14.6 - 19.1	18.5	154.3	88
8204	4	14.8 - 20.6	18.5	15.7 - 21.7	26.6	198.4	113

# hardrock accessories



**Trunk supports with straps**  
ITEM # SP010 - SP011  
Provides additional trunk support



**Pommel**  
ITEM # PL020 - PL021  
Encourages hip abduction



**Tray retaining strap set**  
ITEM # ST056  
Secures the tray and keeps the tray in the desired position



**Moulded pelvic support**  
ITEM # SP017 - SP019  
Provides snug contoured support



**Samba style headrest**  
ITEM # HT014 - HT015  
Provides extra support for the head  
Can be shaped by adjusting the sides  
Available in two sizes:  
Size 1 - 12.7 (w) x 4.7 (h)  
Size 2 - 15.2 (w) x 4.7 (h)



**Footplate & heel huggies**  
ITEM # FP017 - FP019  
Provides extra foot support

Hardrock chair comes complete with mobile base, 4 point pelvic belt and either a high or low back (8203LB) slotted upholstery as standard.





# heathfield

## The perfect start

Heathfield is the perfect starter chair for very young children with sizes up to young adults who require minimal levels of postural support when seated. Its unobtrusive design means that it fits well into nursery, school and home environments.

## A natural choice

We believe in wood as a natural material for our chairs. Wood is extremely durable and it holds a contemporary beauty that makes it aesthetically pleasing while being environmentally friendly. Our timber comes from sustainable sources and offers thermal properties that make it warm to the touch.

## Meeting your child's needs

The Heathfield and its many accessories work in partnership together to provide support and comfort for your child. We recognize that every child is different and the numerous configurations of the Heathfield will ensure that the chair is tailored to your child's needs.



The Heathfield chair comes complete with a buckle pelvic strap, adjustable armrests and a contoured seat.

## Heathfield technical data

all dimensions in inches unless otherwise stated

Item #	Size	Seat to floor* height	Width	Seat depth	Back height	Max user weight (lbs)	Product weight (lbs)
6901	1	7.1 - 9.1	9.4	7.1 - 9.4	9.8	55.1	11
6902	2	7.9 - 11.8	11.0	8.7 - 12.2	11.0	99.2	13
6903	3	9.4 - 14.6	12.8	10.2 - 13.4	12.6	110.2	18
6904	4	11.4 - 15.4	14.4	12.6 - 15.7	14.4	132.3	35
6905	5	12.8 - 16.7	17.1	14.6 - 18.1	16.5	154.3	44

\* Height of chair with contoured seat. The height with a flat seat is 1 inch less

# heathfield accessories



## Skis

ITEM # SK001 - SK005

Provides greater stability to avoid tippy-ness



## Ski & full footrest

ITEM # SK023 - SK027

Provides foot support and offers greater stability



## Mobile dolly base

ITEM # DL006 - DL010

Easy to move with swivel multi-directional casters



## Reversible footboard

ITEM # FB006 - FB010

Foot support that prevents unwanted chair movement



## Adjustable footrest

ITEM # FR005 - FR009

Easy to adjust footrest  
The sides of the footrest help to keep feet within the chair



## Minimum raise mobile base

ITEM # MB005 - MB009

Facilitates standing transfer  
Easy to maneuver  
Only available with sizes 3 - 5 chairs



## Four point harness

ITEM # HN001 - HN004

Supports the trunk and can provide stability.



## Groin harness

ITEM # HN039 - HN041





# heathfield accessories



**Pelvic cushions – double thickness (pair)<sup>1</sup>**  
 ITEM # CS050 - CS053, CS230-  
 CS234, CS077 - CS080  
 Decreases seat width  
 Available in various sizes



**Pelvic cushions – single thickness (pair)<sup>2</sup>**  
 ITEM # CS005 - CS008, CS014 -  
 CS017, CS023 - CS026  
 Provides hip and thigh support  
 Available in various sizes



**Pommel<sup>5</sup>**  
 ITEM # PL001 - PL002, PL013 -  
 PL014  
 Encourages hip abduction



**Footplate & straps<sup>3</sup>**  
 ITEM # FP001 - FP005  
 Ensures feet are firmly in position



**Knee blocks<sup>3,5</sup>**  
 ITEM # KN001  
 Maintains knee position  
 Encourages hip abduction  
 Only available with sizes 3 - 5 chairs



**Adjustable height push handle**  
 ITEM # PH010 - PH014  
 Adjusts to achieve optimum push position.  
 To be used in conjunction with a Mobile dolly base or Minimum raise mobile base



**Tray<sup>4</sup>**  
 ITEM # TR001 - TR005  
 Promotes trunk support  
 Additionally can be used for activities, playing and feeding



**Quick release tray<sup>6</sup>**  
 ITEM # TR101 - TR104  
 The tray comes in white and only available on chairs sizes 1-4

1 Available in sizes 1+1in, 1.5+1in & 2+1in  
 2 Available in size 1in, 1.5in & 2in  
 3 Only available in conjunction with a Mobile dolly base, Reversible footboard or Skis with half & full footrest  
 4 Heathfield chair sizes 1 & 2 must have a suitable stabilizer (footrest, mobile dolly base or skis) when attaching trays  
 5 The Pommel and Knee Blocks cannot be used together  
 6 Heathfield chair sizes 1 & 2 must have a suitable stabiliser e.g. footrest/dolly/skis in order to accommodate tray

# corner chair



## Maximum adjustability

The Corner Chair offers high level of adjustability in the back, side angle, side pad, headrest and pommel. This means that the chair can be positioned to suit your child's individual needs while also enabling the chair to easily grow with your child. Maximum user weight of 187lbs.

## Floor level support

Our Corner Chairs are ideal for young children who need to develop sitting balance. During floor sitting some children are inclined to fall back or sideways if they overstretch or lose concentration. Our Corner Chairs are designed to provide support at the back and sides of children to improve their sitting balance. This encourages social interaction and allows them to engage in floor-based activities without the risk of falling over. The pommel at the front is designed to keep legs abducted to promote a stable posture.

## Corner Chair technical data

all dimensions in inches

Item #	Size	Height range	Width	Seat depth
5501	1	16.1-20.4	15.7	11.8
5502	2	20.4-25.9	15.7	11.8
5503	3	21.7 - 27.2	17.7	13.7

# hip spica

## Support and comfort

Our range of Hip Spica chairs has been specifically designed for young children who are in plaster casts following hip surgery and require supportive seating.

## Portable Hip Spica chair

The new design offers high levels of adjustability and creates a lightweight solution. The Portable Hip Spica features a new slimline design and can easily be dismantled so it's simple to transport. It is supplied with a 5-point harness and quick release tray as standard.



## Portable Hip Spica chair technical data

all dimensions in inches

Item #	Size	Seat height	Footprint	Tray size	Max user weight lbs	Product weight lbs
5596	1	8.3 - 14.2	22.0x26.0	21.7x17.3	55	22



# felix

## simple stackable school chair

# felix

### Felix technical data

all dimensions in inches unless otherwise stated

Size	Seat to floor height	Seat Width	Seat depth	Max user weight (kg)	Product weight (kg)
1	10	11 1/2	8 1/2	165	8
2	12	13	10 1/2	176	10.5
3	14	14 1/2	12 1/2	198	14
4	16	16	14 1/2	242	18
5	17 1/2	16	14 1/2	242	22

Colours	Size 1 Item #	Size 2 Item #	Size 3 Item #	Size 4 Item #	Size 5 Item #
pink	8166	8167	8168	8169	8170
teal	8171	8172	8173	8174	8175
lime	8176	8177	8178	8179	8180
cobalt	8181	8182	8183	8184	8185
red	8101	8102	8103	8104	8105
blue	8161	8162	8163	8164	8165



### Comfortable learning

Standard classroom chairs can be uncomfortable for a whole day of learning but Felix comes with a seat and back cushion all in one, this gives that little extra padding on the seat and back. The Felix chair provides postural support when needed, when a child is comfortable learning becomes more effective.

### Simple features

Felix is stackable, an important feature for any classroom at the end of a working day. The cushions are easily removable and wipeable. They come in six vibrant colors and the chair comes in five sizes. Felix also comes flat packed with easy to follow assembly instructions reducing packaging and making it easier for delivery and handling.

### Classroom chair

Felix has been designed as an active classroom arm chair. The lateral side arm rests not only provide support while seated but it also facilitates the sit to standing movement and vice versa. The shape of the seat and back promotes good posture and the design of the chair legs provides stability and prevents tipping.





# juni



## for dynamic learning

Whether in the classroom, nursery, or at home, good posture when seated creates a positive experience for your child; fine motor skills develop, confidence increases and the ability to engage and learn becomes easier. The Juni chair has a contemporary appeal that helps to promote social inclusion.

### Highly adjustable

We understand that your child's needs change during each stage of growth and development. Seat height and depth as well as armrest height can all be easily adjusted. The backrest can be reclined by 5° increments (from 95° to 105°), while it also features an unique built-in lumbar support.

### Posture at its foundation

Juni's seat and backrest both provide unique contouring. This promotes better posture, gives higher levels of comfort and helps your child feel more secure and stable in the Juni. It is our vibrant chair for children who require minimal levels of postural support when seated.

The Juni chair comes with contoured seat and backrest, built-in lumbar support, pelvic strap, height and depth adjustable seat, height adjustable armrests as well as angle adjustable backrest as standard.

### Juni technical data

all dimensions in inches unless otherwise stated

Size	1	2	3	4
Seat to floor height	6.3 - 8.7	7.9 - 11.0	9.4 - 13.4	11.8 - 15.7
Width	9.4	11.0	12.8	14.4
Depth	7.1 - 9.4	8.7 - 11.8	10.2 - 14.2	12.6 - 16.5
Back height	10.2	11.4	12.8	15.7
Back angle (°)	95/100/105	95/100/105	95/100/105	95/100/105
Max user weight (lbs)	66.1	88.2	110.2	132.3
Product weight (lbs)	9	13	17	22

Color	Item #'s			
Blue	16031	16032	16033	16034



# juni accessories

We've worked in close collaboration with therapists, parents and children to ensure that our products meet and surpass your expectations. Through your valuable feedback the Juni also has companions: highly adjustable Juni Table, Juni Hi & Lo Boosters and Juni Hi Lo Base to overcome height issues at home, nursery & school.

### Juni Table

The Juni table offers two key benefits; the legs are adjustable so your child can work or play at the correct height and the table folds, which allows for easy storage. Perfect companion to your favorite Juni chair.



### Juni table technical data

all dimensions in inches unless otherwise stated

Size	1	2
Height	12.2 - 17.7	15.7 - 23.6
Width/length	27.6	30.7
Depth	20.9	23.2

Color	Item #	
Blue top	2431	2432
Natural top	2421	2422

\* Castors with brakes are sold as an accessory (Item # JB001); this will increase the height of the Juni Booster by 2.56 inches

### Juni Hi Lo Rolling Base

We understand the challenges of the classroom and home environment. Height adjustment is now easy with our Juni Hi Lo Base. The slimline footprint of the base makes this the ideal solution to fit under most classroom desks. So now, you can use your Juni chair together with the Juni Hi Lo Base by simply attaching it to the plate on top of the base; or use the chair independently where height adjustment's are not needed.



### Juni Hi Lo Base technical data

all dimensions in inches unless otherwise stated

Size	1		2	
Dimension	Min	Max	Min	Max
Seat to floor height	6.3	22.4	7.9	22.4
Lower leg length to footrest	6.3	8.7	7.9	11.0
Push handle height	19.7	39.4	19.7	39.4
Base length and width	25.5 x 20.5		25.6 x 20.5	
Max user weight (lbs)	66.1		88.2	
Product weight (lbs)	23.1		23.1	

Color	Item #'s	
Natural Footrest	HL141	HL142





**Dolly Base**  
ITEM # PH101 - PH104  
Facilitates manoeuvrability of your Juni chair  
Available in 4 sizes



## juni accessories



**Skis**  
ITEM # SK101 - SK104  
Helps to stabilize and prevent chair movements



**Mobile skis & footrest**  
ITEM # MK101 - MK104  
Gives clearance to facilitate standing transfer. Includes a sliding footrest & push handle.



**Ski & footboard<sup>1</sup>**  
ITEM # SK111 - SK114  
Provides foot support and offers greater stability



**Footrest**  
ITEM # FR051 - FR054  
Height and angle adjustable footrest. Can be attached to the Juni or used separately.



**4-point harness**  
ITEM # HN231 - HN234  
Provides additional trunk support



**Quick release tray**  
ITEM # TR101 - TR104  
White quick release tray

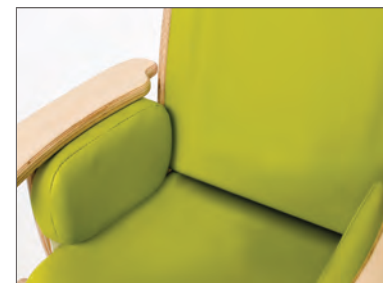

**Side support cushions**  
Provides hip and thigh support  
Available in 1 or 2 inch sizes. Sold as a pair.  
ITEM # - 1 Inch CS531 & CS532  
ITEM # - 2 Inch CS631 & CS632



**Pommel**  
ITEM # PL131 & PL132  
Encourages hip abduction. Can be removed with a hand tool.





# zoomi

## Benefits of Zoomi

- Economical seating solution
- Grows with your child
- Highly adjustable
- Tailored to the needs of your child
- Contemporary design
- Easy to clean
- Stable base with slimline footprint
- Can be used at home and in school

## Our standard Zoomi

The standard Zoomi is ideally suited to the classroom and home. Both the seat and footrest can be easily adjusted to the appropriate height and depth, allowing the chair to accommodate your child's needs as they grow.



## Standard features

- Frame
- Low backrest
- Flat laminated seat
- Laminated footboard
- Pelvic strap

## Zoomi technical data

all dimensions in inches unless otherwise stated

Size	1	
Seat to floor height range	4.3 - 24.2	
Seat width	17.7	
Seat depth	21.7	
Back height	10.2	
Back angle (°)	95/100/105	
Frame height	31.9	
Max user weight (lbs)	187.4	
Product weight (lbs)	35	
Colour	Zoomi standard	Zoomi +
Blue	13031	13032

## Perfectly customizable

With multiple options to cater for a variety of users, Zoomi can be uniquely configured to meet the needs of your child. We have put together two simple options:

- Standard Zoomi
- Zoomi+

# zoomi+

## One size fits all

Zoomi's innovative and unique seating system has been designed to grow with your child, covering an extensive age range, all the way up to young adults.

## Zoomi+

Following collaboration with a number of therapists, we have developed Zoomi+. Complete with low back padded cover, armrest, quick release tray, 5-point harness, flat padded seat, slotted footrest and mobile skis, it offers the ideal solution for children who require a little extra postural support.

## Standard features

- Frame
- Low back padded cover
- Armrest
- Quick release tray
- 5-point harness
- Flat padded seat
- Slotted footboard
- Mobile skis



**Armrest**  
ITEM # AR019  
Provides arm support  
Used for the Quick release tray



**Quick release tray**  
ITEM # TR104  
Helps to stabilize trunk  
Available in white only  
Must be used with armrest



# desks

study desk



activity table



## Perfect for school and home

Our range of desks have been designed to fit in to the school and home environment. The contemporary beauty of wood and the quality of the design enables our desks to stand the test of time.

## Study Desk

The Study Desk has been cleverly designed to allow your child to take part in various activities. The desk also contains ample storage space, so books and toys can be hidden away after they have been used. The Study Desk can be used with a variety of chairs, including the Heathfield, Brookfield and Juni.

## Study Desk technical data

all dimensions in inches

Item #	Size	Height range	Width	Depth	Max user weight (lbs)	Product weight (lbs)
6967	1	13.6 - 20.5	17.7	23.6	176	42
6968	2	20.5 - 32.3	21.7	29.5	176	42

## Practical and easy to store

Our Activity Table is an ideal height-adjustable table for younger children at nursery, school and home. The steel legs can be adjusted in height to ensure good seating posture of your child and can easily be folded for storage.

## Activity Table technical data

all dimensions in inches

Item #	Size	Height range	Length	Width	Max user weight (lbs)	Product weight (lbs)
2251	1	15.2 - 23.4	29.5	23.6	176	26
2252	2	21.9 - 30.1	29.5	23.6	176	26

# wheely stools



adjustable height wheely stool

## Therapist's favorite

The Adjustable Height Stool is our most popular wheely stool. It has been designed specifically for working at lower levels with your child, student or client. The stool is designed for sitting along the narrower side. Available in green and blue with a height range of 13.4 - 18.1in. One size only.

## Adjustable Height Wheely Stool technical data

all dimensions in inches unless otherwise stated

Item #	Size	Color	Width	Height range	Max user weight (lbs)	Product weight (lbs)
4182	Standard	Green & Blue	17.7	13.4 - 18.1	220.5	16





# buddy

## Supportive and affordable standing

Smirthwaite's new stander, the Buddy, is an entry-level vertical stander. Designed for younger children (please see technical data for sizing) who require low to moderate levels of support while weight bearing. Its design allows it to be used as a hip stander suitable for targeted therapy for the development of specific areas such as trunk and shoulder girdle stability and head control.

## Inclusive and accessible

The Buddy stander is slimline so it can be used in schools, enabling your child to perform numerous activities without feeling isolated from friends. Its color and friendly character also brightens up any room. With the economic cost we are delivering an entry-level stander that is an accessible option to everyone.

## Adjustability

The Buddy stander offers numerous height and width adjustments in the chest and pelvic bands as well as additional angle adjustments in the knee supports and sandals. The Buddy size 2 has an additional height adjustment for taller or faster-growing children.

## Buddy stander technical data

all dimensions in inches unless otherwise stated

Size	Size 1 Buddy	Size 2 Buddy 2
Item #	21001	21002
Thoracic support (top) to foot board height	18.9 - 24.4	27.6 - 37.0
Pelvic support (top) to foot board height	13.8 - 18.1	19.9 - 29.3
Knee supports (top) to foot board height	7.1 - 13.4	6.3 - 22.0
Foot board to floor height (excluding sandals)	4.7	4.7
Max width (between thoracic supports)	17.7	17.7
Tray size (depth and width)	16.3 x 20.5	16.3 x 20.5
Base frame (length, width and height)	25.6 x 19.6 x 30.9	31.5 x 24.6 x 39.1
Base frame (length, width and height) (high setting)	N/A	31.5 x 24.6 x 43.8
User weight limit (lbs)	88.2	132.3
Product weight (lbs)	30.9	46.3

Buddy and Buddy 2 come complete with tray, chest band, pelvic band, knee supports and sandals. Straps and tray only available in lime.



# star

## The Star a vertical and prone stander

The physiological benefits of standing are enormous – not to mention the psychological benefits of being able to tackle activities. The Star aims to make standing enjoyable and practical for your child, while making it simple to achieve.

The Star is a vertical and prone entry-level stander that enables children from five years old to young adults to gradually develop and maintain their ability to weight bear by promoting excellent symmetry. It is suitable for children who require lower to higher levels of postural support and control. The Sta is ideal for both school and home environments.

The Star offers high levels of adjustment. Anterior, pelvic and knee supports are height, width and angle adjustable to achieve correct positioning. Pelvic obliquity can be managed through the pelvic support, which incorporates a de-rotational feature.



## Star technical data

all dimensions in mm unless otherwise stated

Size	Size 2 Star
Code	21003
Thoracic support (top) to foot board height	690-1005
Pelvic support (top) to foot board height	550-800
Knee supports (top) to foot board height	223-343
Foot board to floor height (excluding sandals)	194
Max width (between thoracic supports)	460
Tray size (depth and width)	420 x 506
Base frame (length, width and height)	1006 x 660 x 1200
Base frame (length, width and height) (high setting)	1006 x 660 x 960
User weight limit (kg)	60
Product weight (kg)	28

Tilt angle on Sta: 40° - upright.





# bath corner chair

The Bath Corner Chair comes complete with velcro pelvic strap, adjustable pommel, telescopic back rail and telescopic handrail as standard.



## More support

Our Bath Corner Chair is designed for children who require a little extra help with sitting balance when bathing. This is achieved by its angled back and hand rail, both of which provide additional security.

## Adjustable

Like the Bath Chair, our Bath Corner Chair provides numerous levels of adjustment. The pommel and pelvic strap can be adjusted to suit each individual child's needs.

## Compact

Lightweight and easy to clean, the Bath Corner Chair has a perfectly compact design. This allows it to sit low in the bath enabling your child to fully extend their legs in complete comfort. Its size also enables it to fit a wide range of baths.

## Bath Corner Chair technical data

all dimensions in inches unless otherwise stated

Size	1	2
Item #	7511	7512
Seat height	3.0	3.0
Seat width	13.4	13.4
Seat depth	11.0	13.0
Back height	13.8	18.1
4 Pommel settings (distance to back of pommel)	4.3 / 5.1 / 6.3 / 7.5	5.5 / 6.7 / 7.9 / 9.1
Max user weight (lbs)	66.1	77.2
Product weight (lbs)	6.6	8.8





# combi



### Progressive toileting

Our Combi toiletting chair is a great starter chair. Its design enables it to be used as a supportive chair while at the same time providing numerous features to assist your child with the everyday toileting needs.

### Providing solutions

The Combi toiletting chair's design also incorporates a potty for younger children. This can easily be removed to provide a commode seat for children who have progressed their toilet training.

### Adjustability

Good levels of adjustability are offered with the Combi toiletting chair so that a wide range of needs can be met. Seat height and depth can be adjusted to suit the needs of your child.

The Combi Chair comes complete with potty, plastic commode seat, upholstered seat and velcro pelvic strap as standard.

### Combi technical data

all dimensions in inches unless otherwise stated

Size	1	2	3	4
Item #	7551	7552	7553	7554
Seat to floor height*	8.5 - 11.4	10.8 - 14.8	11.8 - 15.7	13.4 - 17.7
Seat width	11.4	12.8	14.4	17.1
Seat depth	8.1 - 11.4	9.6 - 14.0	12.2 - 15.2	13.8 - 17.3
Back height	12.8	14.6	15.7	19.7
Max user weight (lbs)	77.2	99.2	121.3	143.3
Product weight (lbs)	24.3	28.7	30.9	33.1

\*Seat height to floor is to the top of upholstered seat (deduct 1in for the height of the Potty and deduct 1.6in for the height of the Commode seat)

# combi accessories



**Skis & full footrest<sup>1</sup>**  
ITEM # SK037 - SK040  
Provides foot support and offers greater stability



**Reversible footboard<sup>1</sup>**  
ITEM # FB023 - FB026  
Provides foot support  
Prevents unwanted chair movement



**Independent adjustable footrest<sup>1</sup>** ITEM # 4187  
Portable, height and angle adjustable  
Solid support for the feet



**Skis**  
ITEM # SK051 - SK054  
Provides greater stability



**Footrest & straps<sup>1</sup>**  
ITEM # FP002 - FP005  
Ensures feet are firmly in position



**Splash guard**  
ITEM # SG001 - SG002  
Assists in leg abduction and keeps toileting contained  
Requires Toggle handrail



**Pelvic cushions single or double thickness (pair)<sup>2</sup>**  
Provides hip and thigh support  
Available in various sizes



**Toggle handrail**  
ITEM # HR014 - HR017  
Allows child to hold and maintain balance and to sit with minimal support



**Tray**  
ITEM # TR003 - TR006  
Provides trunk support  
Additionally can be used for activities such as playing

<sup>1</sup> Only available in conjunction with a Mobile dolly base, Reversible footboard or Skis with half & full footrest  
<sup>2</sup> Available as double cushions (pair) size 1+1in, 1.5+1in & 2+1in and singular cushions (pair) size 1in, 1.5in & 2in - please ask for ITEM #s

# easi-lift changing bench

## No floor fixing

Most height-adjustable changing tables require fitting to both the wall and floor. The Easi-Lift Changing Bench has been designed to require wall fixing only. This is particularly beneficial where the type of floor, surface pipe work or cabling prevent floor installation.

## Reduces back injury

The Easi-Lift Changing Bench has a travel range of 17.7 - 37.4 inches to meet varying needs and the bench can easily be set to a safe and suitable working height to help prevent the risk of back injury to the carer.

## Space saving design

Easi-Lift Changing Bench is a compact, electrically operated wall-mounted changing bench designed to fit in a dry room environment where space is at a minimum, folding away to save space after use.

## Technical data

- No floor fixing required
- Weight capacity of 330lbs
- Travel range of 17.7 - 37.4 inches



## Standard key features



Electrically operated



Folds away to save space



Stowaway safety rail



Requires wall fixing only

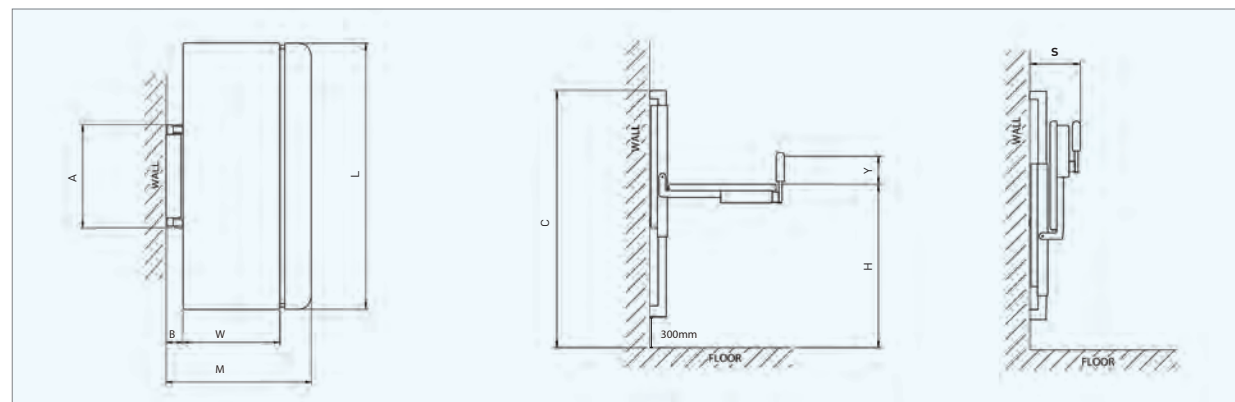

Code Item #	Size	User Weight lbs	Table Dimensions			Travel Range H in	Wall Frame	Wall Frame	Wall Frame	Safety Side Height Y in	Stored Width S in
			L in	W in	M in		Width A in	Depth B in	Height C in		
3086	6	330	66.9	25.6	43.7	17.7 - 37.4	27.6	4.3	63.8	6.5	12.0



# hi-riser

(powder coated for dry rooms and stainless steel for bath rooms)



## Robust yet slimline

Hi-Riser is an electrically operated wall-mounted changing table that is suitable for children and adults of up to 441lbs. Despite its robust structure, the Hi-Riser has a slimline design that ensures it fits easily into most environments.

## Easy transfers

The Hi-Riser has been designed so that it can be used with most mobile or ceiling hoists. The unique safety side rail stows away, streamlining access for transfers from a wheelchair, shower and toileting chair. The Hi-Riser also benefits from an impressive travel range of 24in in height.

## Providing options

We understand that every need is different, which is why the Hi-riser comes in seven different sizes that cater from young children through to adults. The Hi-Riser comes in a cream powder coated frame for dry-rooms or stainless steel frame for bath-rooms (not suitable for direct water contact).

# hi-riser

## key features



- Electrically operated
- Wall and floor mounted
- Cream powder coated frame for dry rooms
- Stainless steel for bath rooms
- Weight capacity of 441lbs
- Impressive travel range of 24"
- Folds away to save on space
- Easy to clean padded surfaces
- Wall mounting kit included
- Stowaway side rail

Mild Steel Powder Coated	Stainless Steel	Size	User Weight	Table Dimensions			Travel Range	Wall Frame Width	Wall Frame Depth	Wall Frame Height	Safety Side Height	Stored Width	Shipping Weight
Item #	Item #		lbs	L in	W in	M in	H in	A in	B in	C in	Y in	S in	lbs
3043	3053	3	441	55.1	23.6	36.4	15.7 - 39.4	27.6	4.3	61.0	6.5	12	185.2
3047	3057	7	441	70.9	25.6	38.4	15.7 - 39.4	27.6	4.3	61.0	6.5	12	202.8

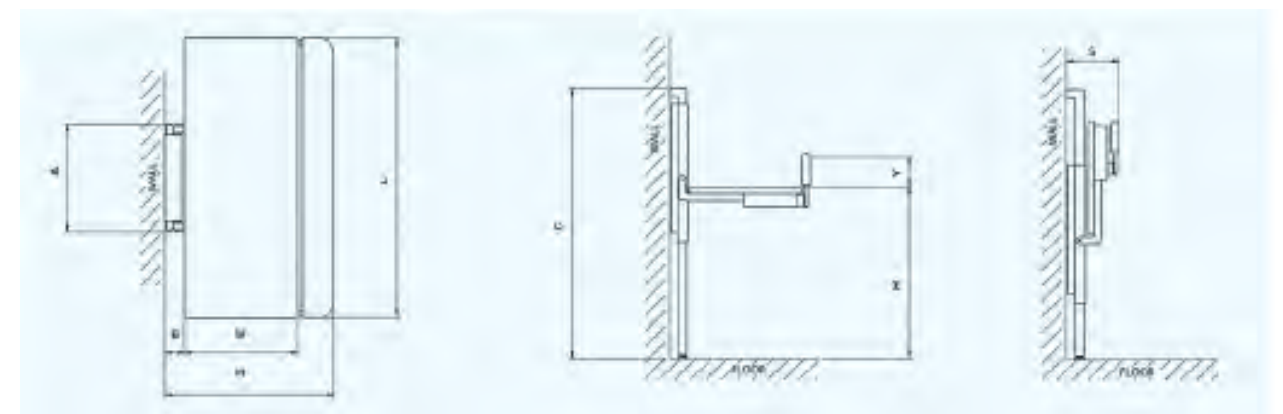

# hi-riser shower stretcher



# hi-riser shower stretcher

## key features



- Electrically operated – handset works safely in wet rooms
- Changing and showering in one
- Drainage pipe & fasteners included
- Wall and floor mounted
- Stainless steel construction
- Weight capacity of 331lbs
- Travel range of 22.4" in height
- Easy to clean padded surfaces
- Unique stowaway side rail
- Folds away to save on space
- Only protrudes 11.8" from the wall when stored

Shown on Easi-lift changing bench

Stainless Steel	Size	User Weight	Table Dimensions			Travel Range	Wall Frame Width	Wall Frame Depth	Wall Frame Height	Safety Side Height	Stored Width	Shipping Weight
Item #		lbs	L in	W in	M in	H in	A in	B in	C in	Y in	S in	lbs
3067	2	331	70.9	25.6	43.7	15.4 - 37.8	27.6	4.3	61	6.5	11.8	181

### Two in one

The Hi-Riser shower stretcher is an easy to use two-in-one wall and floor mounted showering and changing table. Its robust yet slimline design makes it suitable for children and adults of up to 330lbs. Its versatility means it offers the ideal solution for swimming, hydrotherapy and bathroom environments.

### Comfortable & hygienic

The Hi-Riser Shower Stretcher has been designed with reinforced PVC, making it highly supportive yet soft and comfortable to lie on. Its stainless steel frame facilitates easy cleaning, making it a perfect choice for multi-user environments.

### Quick drainage

The Hi-Riser Shower Stretcher is supplied with flexible pipe work to use with a suitable floor drain or, alternatively, it can be plumbed in. Water can easily be drained away using the drainage pipe, which can also be detached for cleaning purposes.

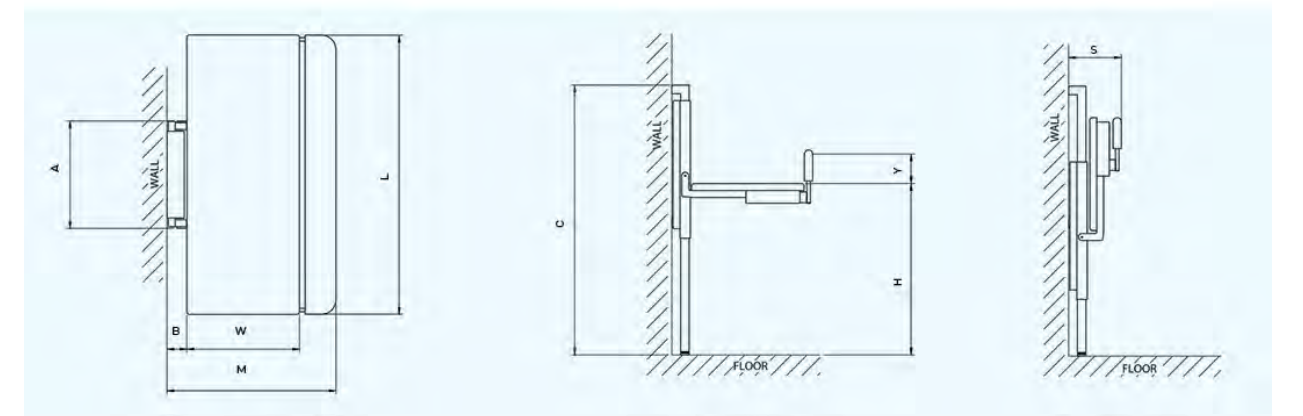



# mobi changer



This image shows the product in a stainless steel option

## Room to room

The Mobi Changer is a fully mobile changing table that requires no installation or attachments. Its compact and slimline design means it can be easily maneuvered from room to room, offering an extremely cost effective option for multi-transfer or multi-user environments.

## Height adjustable

The electrically operated Mobi Changer provides an excellent travel range of 37.4in in height and can be lowered and elevated at the touch of a button. Safe and suitable working heights can be easily achieved which helps prevent the risk of back injury to the caregiver.

## Easy transfers

The Mobi Changer has been designed to ensure sufficient clearance for a wide number of hoists. Its mobility and unique stowaway side rails enable safe and easy handling. Whether you are transferring from a bed, wheelchair or toileting chair, the Mobi Changer is the perfect solution.

# mobi changer

## key features



This image shows the product in a powder coated option



- Mobile and easy to maneuver
- No installation required
- Cream powder coated frame for dry rooms
- Stainless steel for wet rooms
- Available in 2 sizes
- Length of table available 55.1in or 70.9in
- Weight capacity of 500.4lbs
- Travel range of 37.4in in height
- Easy to clean padded surfaces
- Optional angled back
- Unique stowaway side rails

Mild Steel Powder Coated	Stainless Steel	Size	User Weight	Table Dimensions		Travel Range	Safety Sides		Safety Sides Operational Space	Castor Centres	Nominal Clearances	Shipping Weights	
Item #	Item #		lbs	L in	W in	H in	Width X in	Height Y in	Z in	P in	Q in	G in	lbs
3121	3141	1	275.5	55.1	29.5	18.5 - 37.4	33.1	6.5	7.9	42.9	27.6	7.5	189.6
3123	3143	3	275.5	70.9	29.5	18.5 - 37.4	33.1	6.5	7.9	42.9	27.6	7.5	198.4

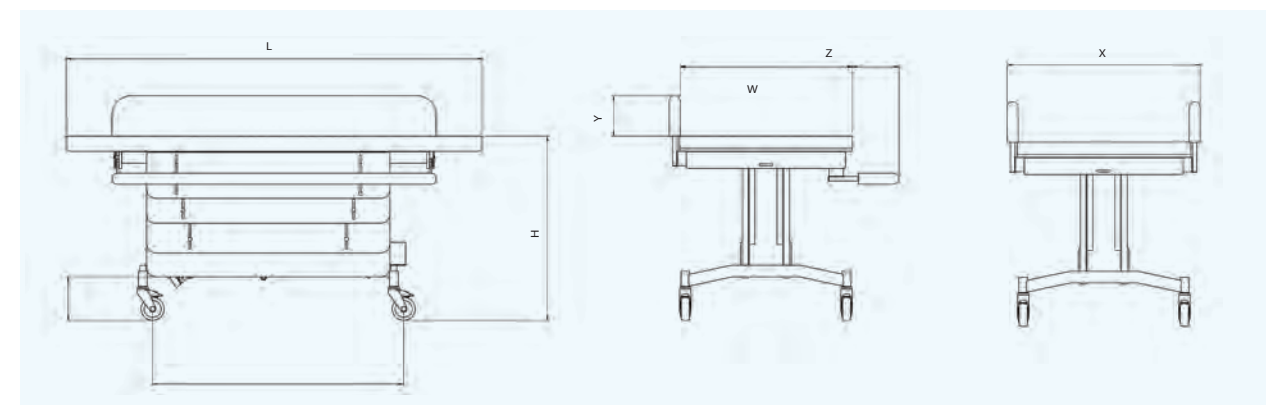

# mobi heavy duty changer



# mobi heavy duty changer

## key features



- Mobile and easy to maneuver
- No installation required
- Electronically operated
- Cream powder coated frame for dry rooms only
- Length of table available in 78.7in
- Weight capacity of 1000lbs
- Travel range of 36.2in in height
- Easy to clean padded surfaces
- Unique stowaway side rails
- Wall mounted charger and 2 batteries come as standard

Mild Steel Powder Coated Item #	Size	User Weight lbs	Table Dimensions		Travel Range H in	Safety Sides		Safety Sides Operational Space Z in	Castor Centres		Nominal Clearances G in	Shipping Weights lbs
			L in	W in		Width X in	Height Y in		P in	Q in		
3161	1	1000	78.7	37.8	21.7 - 36.2	41.3	6.5	7.9	59.1	31.5	5.9	220.5

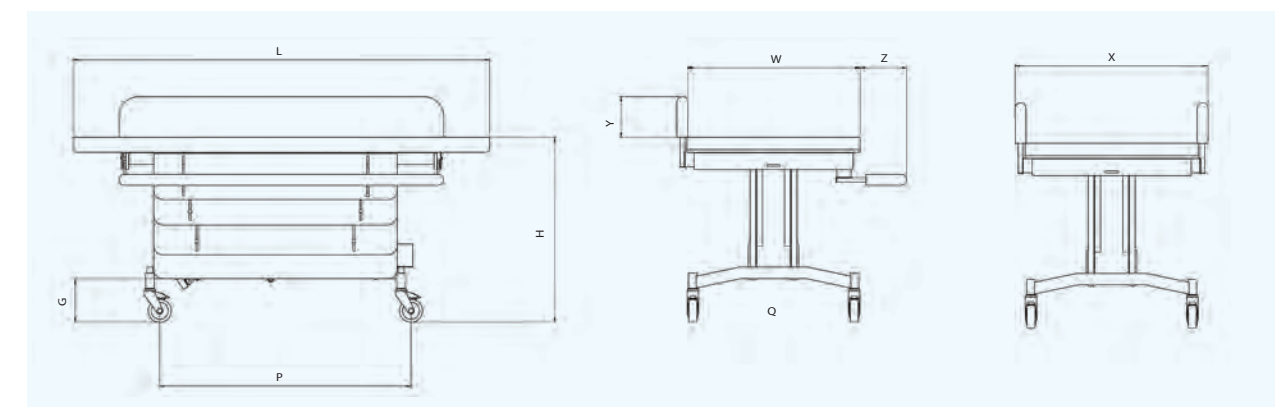

### Meeting bariatric needs

The Mobi Heavy Duty Changer has been designed to meet the needs of bariatric users. Its powerful 12K Newton motor, coupled with the extra wide mattress platform, makes it the ideal solution.

### Maneuverability

The benefit of the Mobi range of products is that they do not require any wall mounting or floor attachments. They are easy to maneuver which means that the user can be transported from room to room with no trouble (door opening has to be 43.3in or more).

### Height adjustable

The Mobi Heavy Duty Changer is electronically operated, which makes adjusting the height of the table simple, this is beneficial for both the caregiver and user.



# mobi shower trolley



## Safe showering

For many children and adults, conventional methods of bathing and showering can be difficult and even hazardous. The Mobi Shower Trolley is a powered, height-adjustable shower trolley specifically designed to enable the user to be safely and easily washed or showered by their caregiver.

## Reduces back injury

The Mobi Shower Trolley offers a range of height adjustments to enable the caregiver to shower and change the user at a safe and suitable working height. This reduces the risk of back injury for the caregiver.

## Stowaway side rails

The Mobi Shower Trolley has been designed with two unique safety side rails that can be easily stowed away beneath the trolley. This allows maximum clearance for safe, easy transfer and use.

# mobi shower trolley

## key features



- Mobile and easy to maneuver
- No installation required
- Stainless steel frame
- Drainage channel and pipe
- A soft comfortable mattress and wedge shaped pillow
- Available in 1 size
- Length of table is 70.9in
- Weight capacity of 485lbs
- Travel range of 36.4in in height
- Easy to clean padded surfaces
- Unique stowaway side rails



Stainless Steel	Size	User Weight	Table Dimensions		Travel Range	Safety Sides		Safety Sides Operational Space	Castor Centres		Nominal Clearances	Shipping Weights
			L in	W in		Width X in	Height Y in		P in	Q in		
3151	1	275.5	70.9	29.5	18.3 - 36.4	33.1	7.7	7.9	42.9	27.6	7.5	189.6

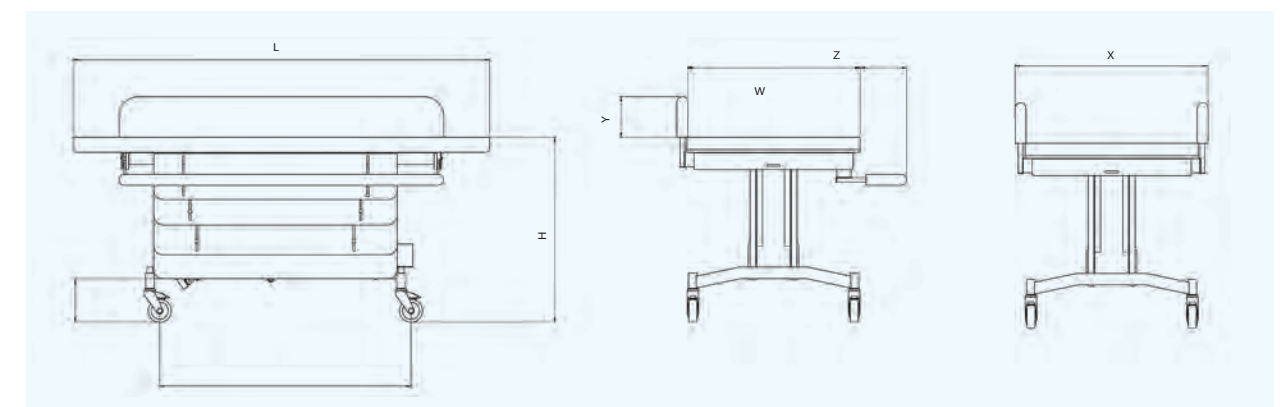

# shower stretcher fixed height



## Economical solution

The Shower Stretcher Fixed Height is our entry-level product and an economical washing and showering solution for the user. This durable and slimline product represents real value for money.

## Makes bathing easier

The Shower Stretcher Fixed Height is designed to allow the washing or showering of the user while in a horizontal position. It can be fixed directly above a bath making it the perfect solution for the home.

## Added headrest

The Shower Stretcher Fixed Height, along with all of our shower stretchers, can be enhanced with the optional integral vinyl headrest. The headrest features a paddle lift adjustment, which allows it to be locked securely into the desired position.

# shower stretcher fixed height

## key features



- No floor attachments required
- Ideal for a wet room environment
- Stainless steel frame with powder coated finish
- Permanently fixed at the desired height
- Available in 2 sizes
- Length of stretcher available 55.1in & 74.8in
- Weight capacity of 440.9lbs
- Folds away to save on space
- Wipe clean surfaces
- Includes a safety guard

Stainless Steel Powder Coated		Size	User Weight lbs	Table Dimensions			Travel Range	Wall Frame Width A in	Wall Frame Depth B in	Stored Width S in	Product Weight lbs
Without Headrest Item #	With Headrest Item #			L in	W in	M in					

3171	3271	1	440.9	55.1	25.6	39.4	Fixed	26.2	3.1	9.4in	165.3
3176	3276	6	440.9	74.8	25.6	39.4	Fixed	26.2	3.1	9.4in	176.4
3191	3291	1	440.9	55.1	25.6	39.4	Fixed	29.5	4.3	10.6	180.8
3196	3296	6	440.9	74.8	25.6	39.4	Fixed	29.5	4.3	10.6	191.9

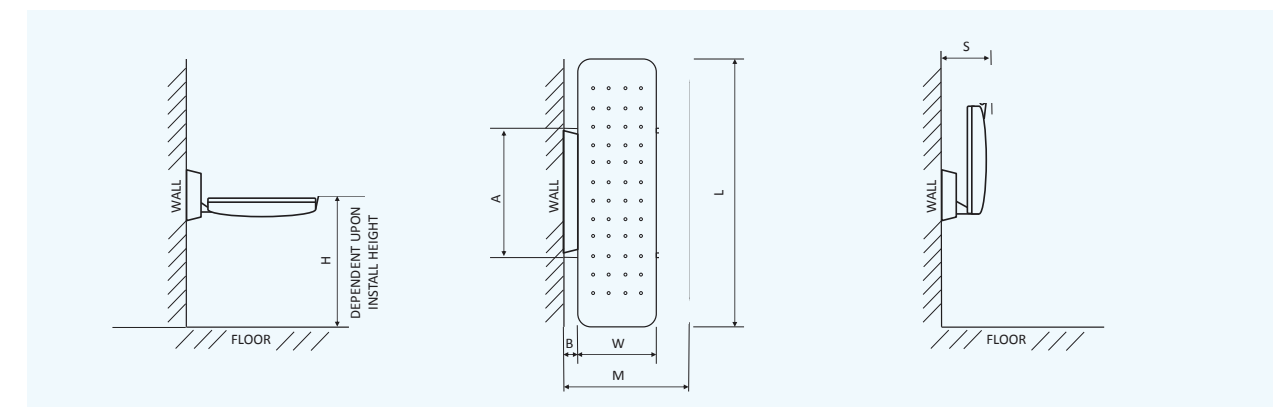



# sandals

## Feet support

Children's feet also require additional support to help maintain the position of their hips. Feet support enhances good balance and enables freedom of movement in the upper body.



Ferndale sandals (pair)  
ITEM # SL001 - SL004  
Available in 4 sizes



Cocoon sandals (pair)  
– velcro<sup>1</sup>  
ITEM # (standard) SL005,  
SL007, SL009, SL011, SL013



Heel huggies (pair)  
ITEM # HH001 - HH005  
Available in 5 sizes



## helping children shine





seating • standing • desks & stools • toileting & bathing • changing & showering

a helping hand around  
the World



always here to help

USA Contact Details:

telephone

212 541 2455

email

info@smirthwaite.com

website

www.smirthwaite.com

Smirthwaite USA LLC

405 Lexington Avenue, 26th Floor

New York NY10174



Smirthwaite reserves the right to modify product specifications at anytime without prior notification.  
All measurements are approximations and can vary depending on the wood and materials used.  
All details shown are correct at time of print. Smirthwaite® is a registered trade mark of Smirthwaite Limited.